

# THE ESSENTIAL DEFENSE AGAINST EDM BEARINGS DAMAGE

RECOMMENDED PRACTICES FOR SHAFT  
GROUNDING WITH EARTHINGS®

**EARTHINGS™**

2026 MANUAL

*\* Harsh Environment \**

# INSTRUCTIONS FOR THE USE OF EARTHINGS® SHAFT GROUNDING RINGS FOR BEARING PROTECTION

## TECHNICAL GUIDELINES AND PROCEDURES FOR ELECTRIC MOTORS

This document outlines a set of engineering best practices applicable to three key areas:

- 1. New Motor Design:** Recommendations for specifications that should be considered during the design phase to ensure optimal protection.
- 2. Motor Repair and Design Specifications:** Technical guidelines applicable to both the repair process of existing motors and the development of new motor versions.
- 3. Measurements and Diagnostics:** Methodology for conducting shaft voltage measurements and protocols for bearing inspection, essential for early detection of potential issues.

## TECHNOLOGY ENSURING THE DURABILITY OF HIGHLY LOADED INVERTER-CONTROLLED MOTORS

### About Earthings® and Shaft Grounding Technology

EarthRings® is the inventor and leading manufacturer of bearing protection rings. Our rings are designed for installation in electric motors and other machines with a rotating shaft to safely dissipate voltages generated by variable frequency drives. The EarthRings® shaft grounding ring technology is used in motors of all sizes, from small fractional horsepower motors to large medium-voltage motors, applied in virtually all commercial and industrial applications. EarthRings® shaft grounding ring technology provides reliable protection for bearings against electrical discharges that cause pitting, frosting, and fluting. EarthRings® rings use specially developed conductive microfibers positioned circumferentially around the motor shaft and housed in our patented EarthRings® channel, which protects them during operation.

### Warranty and Terms of Use

Products are covered by a one-year warranty from the date of purchase, which includes material and manufacturing defects. Defective products will be replaced with new ones, provided that the damage is not a result of improper use or application for an unintended purpose. All declarations and technical information contained herein or provided by the manufacturer or its representative are given in good faith. The user is responsible for determining the suitability of the product for the intended application. The manufacturer is not liable for any direct or consequential injuries, losses, or damages resulting from the use or attempted use of the product.



### Safety and Liability

All safety policies and procedures concerning electric motor repair and work in hazardous conditions must be strictly followed. All appropriate personal protective equipment, as required by law, must be worn. Employers are responsible for informing employees about applicable safety regulations and ensuring their compliance. The manufacturer is not liable for any direct or consequential injuries, losses, or damages resulting from the use, attempted use of the product, or the application of the procedures described in this manual.

No part of this publication may be reproduced, stored in a retrieval system, or transmitted in any form or by any means (electronic, photocopying, recording, or otherwise) without the prior written consent of EarthRings®. An exception is made for a reviewer, who may quote brief passages or reproduce illustrations in an article, provided the source is cited. This manual is generally reviewed and updated annually. All comments and suggestions are welcome. Any errors or omissions should be reported to the editor. Additions and corrections to the printed version of the manual will be included in the next printed edition and published on the EarthRings® website immediately after verification.

#### Disclaimer

The application notes serve as general guidelines to assist in the proper selection of EarthRings® bearing protection rings for safeguarding motor bearings. All statements and technical information contained in the application notes are given in good faith. The user is responsible for determining the suitability of the product for their specific application.

## TABLE OF CONTENTS

**PRODUCT**  
EarthRings® products ..... **4**

**TECHNOLOGY**  
About EarthRings® and shaft grounding technology ..... **9**

**GOOD ENGINEERING PRACTICES (GEP)**  
Standards for new and repaired motors ..... **14**

**CASE STUDY**  
High-frequency shaft voltage measurement ..... **28**

**SOLUTION**  
Selecting the proper ring size ..... **32**

## PRODUCT

### EARTHINGS® OFFERS LV RINGS FOR LOW-VOLTAGE MOTORS AND HV RINGS FOR MEDIUM-VOLTAGE MOTORS

#### PRODUCT APPLICATION

EarthRings are used to protect bearings from the negative side effects of high shaft voltages that are present from modern day variable speed drives (VFD) operated by pulse width modulation (PWM) for both AC and DC motors as well as eddy currents and static currents from driven equipment such as fans, pumps and rollers.

#### PRODUCT FUNCTIONALITY

EarthRings® are placed over the shaft of an electric motor, the aluminum housing is secured to the end-shield of the electric motor (fastening the housing and creating an earthing / grounding point of contact) and the microfiber bristles are circumferentially arranged around the diameter of the shaft and are touching the shaft surface. This contact / and non-contact which allows for a lower impedance path to earth for the shaft voltages, thereby allowing most of the voltage to bypass the bearings by passing through the EarthRings® instead, thereby preventing arcing of the bearings.

#### FRICITION

As described above, extremely low friction based on the correct fiber shaft overlap, creating extremely low fiber pressure and light weight thin diameter of microfiber that lasts for years on all low voltage motors. Even once the fibers have worn to the shape of the shaft electron transfer still allows for static dissipation and electron attraction to carry on dissipating voltages when the voltages get high and cross over the airgap (0.001 mm) between the shaft and fibers due to gaseous exchange.



## LV RINGS - LOW VOLTAGE MOTORS WITH A POWER UP TO 400 KW

Supply voltage from 0,75Kw

EarthRings® LV is for motors up to 400 Kw or 690 V

Recommended product: EarthRings® LV or EarthRings® LV Split

**No INSULATED BEARINGS Required**

### Description:

- LV construction type
- Conductive microfibers arranged in at least two rows
- Thickness up to 10 mm
- Outer diameter specified at the end of the catalog

### Installation:

- Inside or outside
- Matched to shaft diameter
- Full and split versions available
- Optional custom mounting

### Application Recommendations For Low Voltage Motors

The EarthRings® LV is used on all low voltage electric motors up to 690 volts and 400kw and unlike other shaft grounding solutions and manufacturers, EarthRings® will protect both Electric motor bearings from EDM arcing and does not require an insulated bearing or housing up to 400kw.

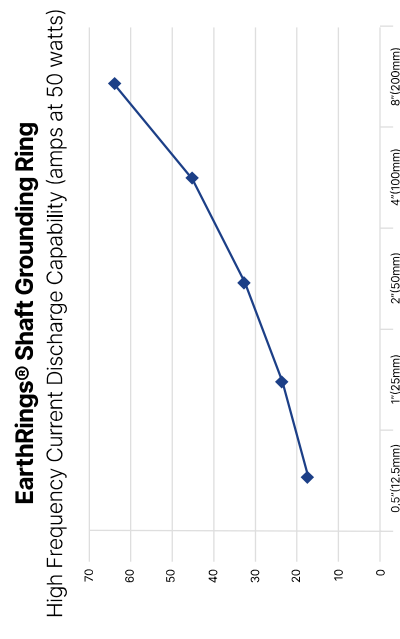
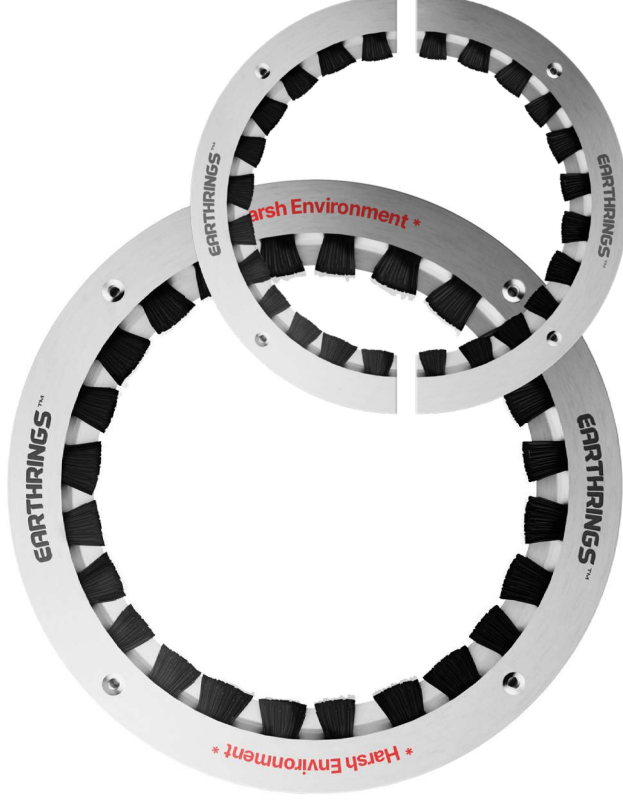

## HV RINGS - HIGH VOLTAGE MOTORS WITH A POWER OF OVER 400KW

High Voltage EarthRings® are custom made for all large electric motors rated above 400 Kw or 690 volts.

- They are 6.5mm thicker than the LV EarthRings®
- HV have 3 x more fiber
- Different materials and are custom manufactured each electrical motor
- Perfect fit based on factors into account such as the KW, Amps, Rpm, Volts, Shaft size etc.

### Dirt and Dust In Operating Conditions

Dirt or dust in most environments has no effect on the fibers and still allows for dissipation of voltages.

### Oil And Grease

Small amounts of oil and grease on the motor shaft are acceptable as the fibers will sweep away the oil and grease, as well as the rotational forces of the shaft dissipating the oil and grease in a very short time period. Fibers will not operate in continuously submerged oil.

### Humidity

0 to 90% Humidity levels are acceptable.



### EarthRings® Shaft Grounding Ring

High Frequency Current Discharge Capability (amps at 50 watts)

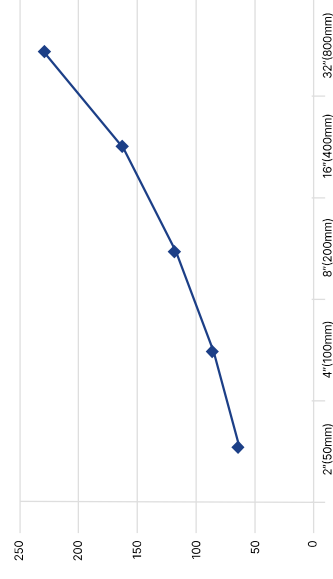

## LV ARC™ - LOW VOLTAGE MOTORS WITH A POWER UP TO 400KW

Supply voltage up to 400 Kw / 690 V

Recommended product: EarthRings® HV or EarthRings® HV Split

### Description:

- HV construction type
- Placement of conductive microfibers minimum
- Thickness approx. 9 mm
- Outer diameter specified at the end of the catalog

### Installation:

- Inside or outside
- Matched to shaft diameter
- Full and split versions available

### Application Recommendations For standard Voltage Motors

The LV Earthrings are made for all electrical motors rated from 0,75Kw to 400Kw and/or motors up to 690 volts.

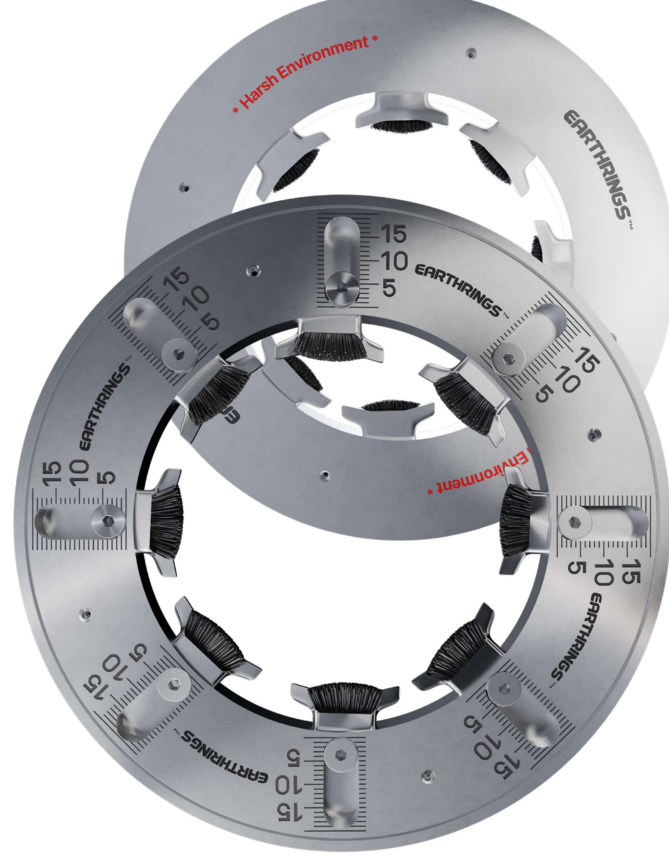

**EarthRings® Grounding Ring**  
High Frequency Current Discharge Capability (amps at 50 watts)

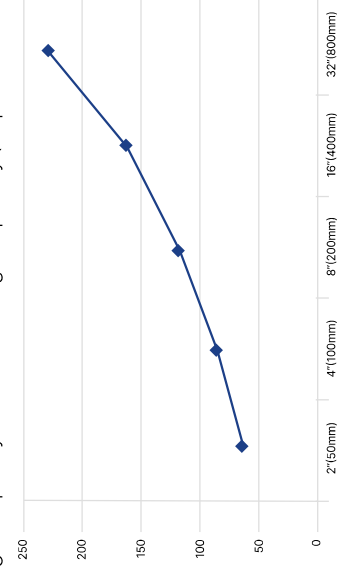

## HV ARC™ - MEDIUM AND HIGH VOLTAGE MOTORS WITH A POWER OF OVER 400KW

The HV ARC is also a revolution in the industry, The HV ARC is an adjustable shaft grounding ring that allows the customer or agent to always have stock on hand and it is the first ready made off the shelf HV shaft grounding ring. No waiting, no excessive pricing.

### Benefits:

- Immediately available – no waiting
- Lower pricing - as is a shelf item
- Fibres over designed for Extra conductivity
- Stronger housing for harsh HV applications
- Solid HV Universal Brackets included
- Gold Booster fibers - 8 x more conductivity

### Maximum Surface Speed / RPM

There is no Maximum surface rate, EarthRings® have been tested and at present theoretically shaft speed is unlimited.

### Maximum Temperature Rating

220 Degrees Celsius is the highest Recommended operating temperature, but our fibers have been used in applications up to 400 degrees Celsius.

### Minimum Temperature Rating

Minus 85 Degrees Celsius is the lowest tested temperature



**EarthRings® Grounding Ring**

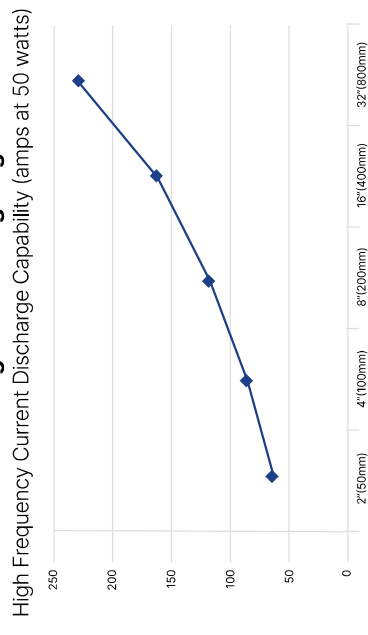

## EARTHINGS® TECHNOLOGY

EARTHINGS® GROUNDING RINGS ARE A UNIQUE PRODUCT THAT PROVIDES GROUNDING BOTH WITH AND WITHOUT CONTACT.

The EarthRings® bearing protection ring uses **revolutionary technology**.



- Unique microfiber ring with circumferential conductivity.
- Multi-row design provides greater reliability.
- Provides unparallel shaft grounding effectiveness.

The patented technology in EarthRings® bearing protection rings provides effective electrical contact. EarthRings technology provides maintenance-free, contact protection, which allows for normal motor bearing lifespan and the most reliable performance of all shaft grounding technologies.



The unique design of EarthRings® shaft grounding rings includes millions of specially designed conductive microfibers. With such a large number of current flow points, the ring provides continuous electrical contact, both when the fibers are in physical contact with the shaft and when they are not.

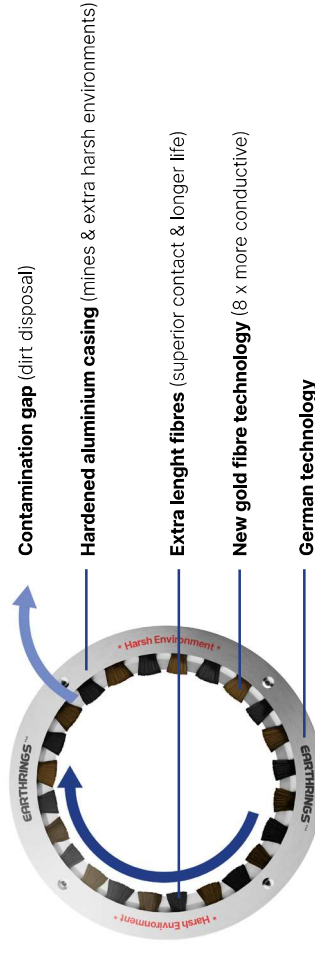

EarthRings® fibers have special properties that ensure current flow without significant shaft wear, yet maintain their characteristics throughout the motor's lifespan of continuous operation. Thanks to their patented design, the microfibers show minimal wear and are resistant to cracking; in tests, they withstood 2 million changes in motor rotation direction without damage. EarthRings® rings are designed to overlap the shaft by 0.76 mm.

## EARTHINGS® BEARING PROTECTION RING COMPARED TO A CONTACT-ONLY BRUSH

Comparison of EarthRings® rings with conventional grounding brushes that only work via contact with the shaft. Thanks to their patented design and special microfibers, EarthRings® rings maintain an electrical connection with the motor shaft even if physical contact is interrupted. No other grounding brush provides such exceptional bearing protection.

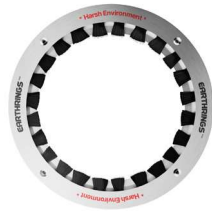

- ✔ No friction or wear, lasts for service life of equipment (no friction to shaft).
- ✔ Shaft Grounding Effectiveness - Continuous discharge - no degradation over time.
- ✔ Surface speed and revolutions per minute do not affect the performance or wear.
- ✔ No measurable dust collected or wear observed (less than 0.025mm).
- ✔ Lasts for service life of equipment - nothing to wear out, estimated life is greater.
- ✔ Never needs to be replaced.
- ✔ Don't cause any motor/equipment shutdown or lost production.
- ✔ Don't need any periodic shaft maintenance.
- ✔ Don't need any brush maintenance.
- ✔ Works If Oil/Grease Gets On Shaft due to microfibers design the fibers penetrate and cut through oil and grease therefore making it far more effective than carbon blocks, plus have thousands of points of contact for more reliable performance in contamination areas. It is not porous so does not hold or absorb contaminants.
- ✔ Micro fiber is optimized for high frequency current discharges produced by VSD dv/dt pulse width modulation (PWM) switching.
- ✔ Simple to install - screw-on brackets - mounts direct to end shield. Self-centers for easy alignment, slim design minimizes shaft length requirement.
- ✔ Guarantee certificate supplied - Bearings on motor's guaranteed not to fail from bearing fluting caused by electrical bearing discharges.
- ✔ No load on shaft - micro fibers „lightly“ touch shaft surface.
- ✔ Three to four times greater Effective Conductive Surface Contact, hundreds of thousands of micro fibers surround shaft.



- ✘ Wears out due to friction
- ✘ Shaft Grounding Effectiveness decreases after a few weeks due to coating buildup on shaft. Must be cleaned to restore contact.
- ✘ Unsafe in hazardous environments. Not certified.
- ✘ Higher surface speed and revolutions per minute results in faster wear and replacements, /min limitation, less effective at higher /min.
- ✘ Carbon block wear on shaft creates dust particles based on surface rate of shaft. (Creates carbon dust that can damage the bearings)
- ✘ Depends on material but may last for as little as 3 - 5 months.
- ✘ Replacement needed frequently (requires equipment shutdown).
- ✘ Periodic for maintenance or replacement needed.
- ✘ Periodic maintenance needed to clean/remove oxidation/coatings/contamination shaft
- ✘ Periodic maintenance needed to clean/remove coatings/contamination brush contact surface.
- ✘ Does not penetrate oil and grease and may trap contaminants under the carbon block, plus contaminants and oil are easily absorbed by the carbon block as it is very porous.
- ✘ Not as effective for high frequencies as EarthRings®.
- ✘ Complex bracket installation and alignment, may require machining for bracket installation.
- ✘ No performance guarantee
- ✘ Spring load on shaft, causes drag.
- ✘ Effective Conductive Surface have only 15-30% contact on slipping surface.

## INTERNAL MOUNTING OF EARTHINGS®

EarthRings® rings are best installed inside the motor to protect them from contaminants and dust. This is the standard practice for motor manufacturers who factory-install these rings.



**You must follow all safety recommendations. Safety data sheets for EarthRings® are available for download at [www.EarthRingsEurope.com](http://www.EarthRingsEurope.com)**

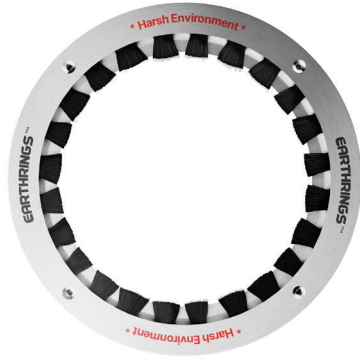

### Mounting by bolting to:

- the bearing retaining cap
- a specially prepared mount



**Do not use non-conductive thread locker.**



### Press fit mounting is possible in:

- the bearing retainer cap or
- in a specially prepared mount.

### Bore dimensions (press fit):

- **Interference fit: 0.05 - 0.10 mm**
- **Metric dimensions:**
  - Ring OD tolerance: +0 / -0.025 mm
  - Bore tolerance: +0.025 / -0 mm
- **Imperial dimensions:**
  - Ring OD tolerance: +0 / -0.001 inch
  - Bore tolerance: +0.001 / -0 inch

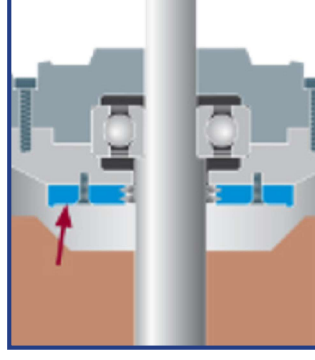

### Drill and tap holes according to the EarthRings® ring's specific drawing. Use either:

- flat-head cap screws or
- socket head cap screws with a lock washer.



### In some motors, using an additional spacer ring may be beneficial to position the ring away from the bearing grease cavity.

Additionally, an extra grease seal can be installed to reduce grease penetration between the fibers.



## EXTERNAL MOUNTING OF EARTHINGS®

EarthRings® rings can also be externally mounted, but they must be protected from excessive contamination and dust.



### Mounting by bolting is possible to:

- the end cover
- a specially prepared mount.

Drill and tap holes according to the EarthRings® ring's specific drawing. Use a socket head cap screw with a lock washer.



**Do not use non-conductive thread locker.**

### Mounting is possible with a standard bracket or with the uKIT bracket.

- Standard brackets (3 or 4, depending on the ring size).
- The uKIT bracket is available with various mounting types.
- Special mounts are also available.

To view the full product line or download the EarthRings® solutions catalog, please visit [www.EarthRingsEurope.com](http://www.EarthRingsEurope.com).

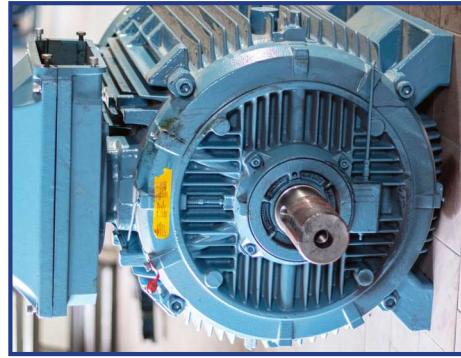

Measure the shaft diameter and select the appropriate size of "ARC Earthing" that matches that diameter (for example, a 90 mm shaft would require the "ARC 80–100 mm" size). Then refer to the ARC Chart for that specific ARC Earthing size, in either Metric or Imperial units, and choose the size that is 2 mm larger than the measured shaft diameter—for instance, if the shaft measures 90 mm, select 92 mm. Identify the corresponding "ARC LINE" number on the chart and record that number or the closest available value. This additional 2 mm ensures that, once installation is completed, there will be a 1 mm gap between all the aluminium brush holders and the rotating shaft.



At the back of the "ARC" ring you will see the "ARC LINES" numbered 1 to 15, your goal is to move the line on the Hexagonal counter sunk screw to the correct "ARC line" number (the number you previously recorded from the ARC LINE CHART), or as close to that number as possible. (Don't worry, you will fine tune later with a Vernia). Insert the Allan key into the counter sunk screw, loosen and ensure the Line on the screw is horizontal with the 1 to 15 lines on the back, then use the Allan key as a lever to move the screw up or down until the horizontal line on the screw is in line with the number you want. Do this with all the "Highly Conductive fibre holders".



Using a Vernia measure all the "Highly Conductive Fibre Holders" diagonally opposite one another, it should measure a diameter of approximately 2mm larger than the shaft size. (e.g. for a 90mm shaft size you should measure close to 92mm diameter for each set of holders). From the front all the "Highly Conductive Fibres Holders" should look even and circular.



Using a "Feeler Gauge" to check the gap between each of the "Highly conductive fibre holders" and the shaft, a gap anywhere from 0,7mm to 1,3mm is acceptable.

## MOTORS UP TO 400 KW – LOW VOLTAGE

### Internal or external mounting.

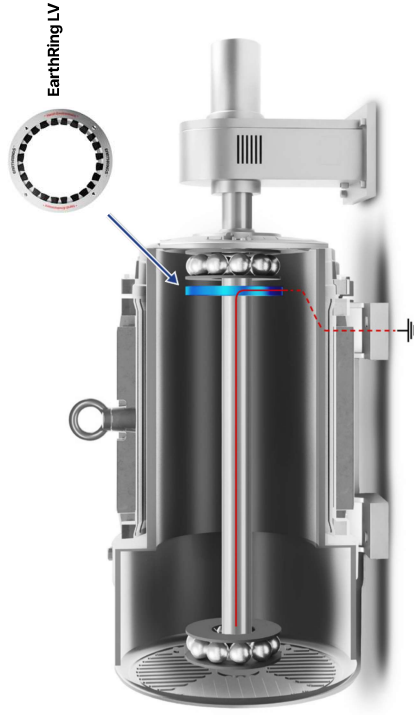

## MOTORS WITH A POWER OUTPUT ABOVE 400KW

### EarthRings® ring should be installed on the opposite side.

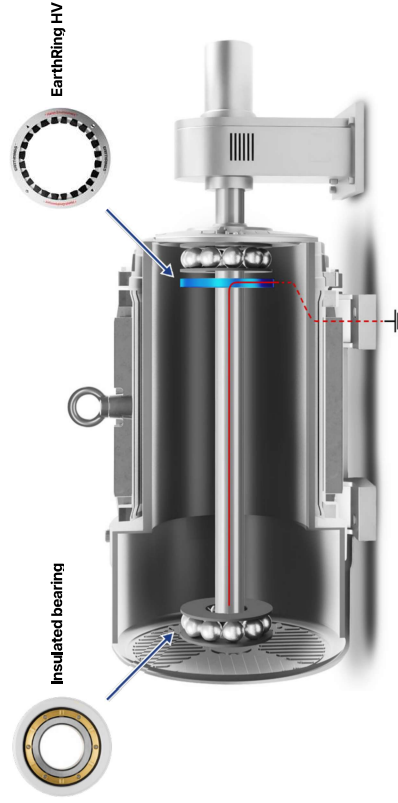

General recommendations: For foot-mounted, face-mounted, or flange-mounted induction motors with single-row radial bearings on both sides of the motor. Motors in the customer's installation can be mounted horizontally or vertically. Install one EarthRings® bearing protection ring on one side of the motor to discharge capacitively induced shaft voltage. The EarthRings® ring can be mounted inside or outside the motor.



**EarthRings® All safety recommendations must be followed. Safety data sheets can be downloaded from [www.EarthRingsEurope.com](http://www.EarthRingsEurope.com)**

**For horizontally mounted motors with single-row radial bearings on both sides of the motor.** Opposite drive side: To interrupt circulating currents... Drive side: Install one EarthRings® bearing protection ring. It can be mounted inside the motor on the bearing cover or externally on the end cover of the motor.



#### Recommended products:

- Low-voltage motors up to 400Kw: EarthRings® LV or LV ARC
- Low-voltage motors above 400Kw: EarthRings® HV or HV ARC

**For motors up to 400Kw and up to 690 volts** :- Install one EarthRings® bearing protection ring, preferably on the drive side, to protect the bearings in the driven equipment (e.g., gearbox , pump, fan bearing , and position encoder ). The EarthRings ® ring can be mounted inside the motor on the bearing cover or externally on the end cover.



#### Recommended products:

- Low voltage motors: EarthRings® LV
- Medium voltage motors: EarthRings® HV

Bearings in the driven equipment may be exposed to shaft voltage induced by a variable frequency drive if EarthRings® rings are not used. Install one EarthRings® bearing protection ring, preferably on the drive side, to protect the bearings in the driven equipment (e.g. gearbox, pump, fan bearing, and position encoder). The ring can be mounted inside the motor on the bearing cover or externally on the end cover of the motor.

**For motors above 400Kw** insulate the NDE bearing and install an HV EarthRings® Ring on the DE (cylindrical roller bearing side).



#### Recommended products:

- Low voltage motors: EarthRings® LV
- Medium voltage motors: EarthRings® HV

## GOOD ENGINEERING PRACTICES (GEP)

### STANDARDS FOR NEW AND REPAIRED MOTORS

#### ANSI/EASA Standard AR100-2010, Chapter 2, Mechanical Repair: Section 2.2 Bearings

According to the ANSI/EASA AR100-2010 standard, the section on mechanical repairs, specifically section 2.2, defines key requirements for bearings. It mandates that bearings be inspected for damage such as pitting, fluting, frosting, point damage, or other defects. If any of these types of damage are found, the bearings must be replaced or properly refurbished in accordance with the standards.

#### Bearing Inspection:

„Bearings should be inspected for damage such as pitting, fluting, frosting, point damage, or other defects.“

#### Services for electric motor repair, testing, and bearing inspection:

Our range of electric motor repair and testing, as well as bearing inspection services, allows us to provide a complete package of solutions to business and industrial clients. Services for motors powered by variable frequency drives are of particular importance. By basing our service offering on the best motor repair and analysis procedures, we have created a beneficial proposition for end-users.

### BEST PRACTICES AND SERVICE OFFERINGS:

## A C E I T

Analyze and provide advice on preventing bearing damage in frequency-controlled motors.

Check bearings for signs of electrical erosion damage.

Exclusive service and customer satisfaction require the highest quality of services.

Inspection of motors with frequency controlled drives requires measurement of the shaft voltage.

The main way to ensure bearing protection after repair is to follow best practices.

#### The Value of Repair and Analysis Services

Clients expect repair, testing, and analysis services that guarantee the reliable operation of their machinery. They often recognize leading specialists in the industry and are willing to entrust their business to them. For this reason, the added-value services described in this manual will help motor repair and servicing companies meet customer expectations by implementing recommended best practices for repairing variable frequency drive motors.

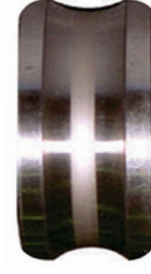

Frosting: a dull matt effect frof arcing



Fluting

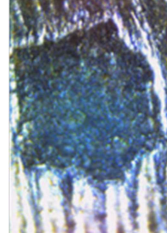

Microstructural Fusion of Steel

## BEST PRACTICES FOR SHAFT GROUNDING! RECOMMENDED PROCEDURE

The best practices described in this manual are intended as guidelines for the motor repair, servicing, and manufacturing industry. Their purpose is to help protect variable frequency drive motors and to establish bearing protection standards for newly designed motors.

- Adding EarthRings® shaft grounding ring technology to any new or serviced VFD-driven motor is the most effective method of shaft grounding, protecting bearings from damage caused by shaft currents and voltages.
- To prevent the formation of high-frequency circulating currents, motors with a power output exceeding 400Kw should be equipped with an LV EarthRing on the Drive End
- Following the recommendations provided in these best practice guidelines will ensure that repaired motors meet the highest standards of performance and reliability.

**This document presents guidelines based on the ANSI/EASA AR100-2010 standard and principles of shaft grounding, aiming to ensure the highest standards in electric motor protection:**

Taking one additional step to ensure a client's business continuity directly translates into their loyalty and satisfaction. Manufacturers and repair workshops that effectively solve problems and guarantee peak motor performance will, in turn, gain interest and recommendations from satisfied customers.

Taking an extra step to ensure a customer's operational continuity builds their loyalty and satisfaction. Motor manufacturers and repair shops that effectively solve problems and guarantee peak performance will, in turn, gain recommendations from satisfied customers.

- Engineers and facility managers expect service and repair shops to keep up with the latest technologies and recommended procedures.
- The EarthRings® shaft isolating ring technology, proven in over a million installations worldwide, is an innovative solution specifically designed to protect bearings from currents induced by variable frequency drives (VFDs). In 2007, this concept won first prize from the IEEE Institute for a paper on the design of conductive microfiber rings for shaft grounding.

**Bearing Inspection Report:** Inspecting and checking every bearing from a motor under repair—especially in units controlled by a variable frequency drive (VFD)—provides key information necessary to determine the optimal repair method. To diagnose damage such as pitting or fluting caused by electrical discharges, it is essential to perform the repair procedures described in this handbook.

- Installing a shaft grounding ring (EarthRings® SGHR or LV) on any variable speed drive motor. Machining the internal or external surfaces for mounting the EarthRings®
- For repaired motors with a power output exceeding 75 kW, insulate the motor bearing using an insulated sleeve, an insulating coating on the bearing housing, or by installing a hybrid or ceramic-coated bearing.

Provision of measurement and analytical services: By offering state-of-the-art measurement and analysis services for variable frequency drive (VFD) motors, we are able to improve the reliability and uptime of any system. Our service includes vibration analysis, thermographic measurement, and, most recently, shaft voltage measurement.

- Shaft Voltage Measurement: Using a portable oscilloscope (e.g., Fluke 190 Series) and an EarthRings® shaft voltage probe kit, a trained technician can easily measure the shaft voltage in any variable speed motor. This allows for an assessment of the probability of electrical discharges occurring inside the bearing.
- The test can be performed:
  - At the plant or facility where the motor is used.
  - Upon the initial motor startup, which allows for the early detection of shaft voltage and the prevention of future failures.
  - After a motor repair using EarthRings® shaft grounding rings to confirm their effectiveness.
  - Periodically, as part of a preventive maintenance program.
- By expanding current vibration analyses, thermographic measurements, or other measurement methods with shaft voltage measurement service, it is possible to enhance the scope of offered services with a significant, high-value-added option for clients. Shaft voltages and bearing currents are induced by variable frequency drives

## ABOUT VFD INDUCED SHAFT VOLTAGES & BEARING CURRENTS

### ELECTRIC MOTORS POWERED BY LINE VOLTAGE

#### Balanced voltage conditions

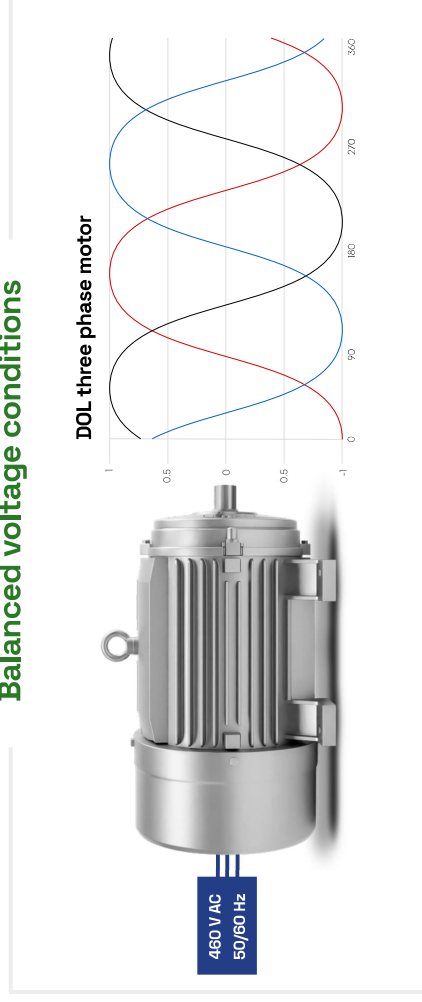

Electric induction motors are designed to be powered by current. Three-phase, with a sinusoidal waveform and a frequency of 50 or 60 Hz.

The supplied power is characterized by a balanced frequency and phase. (120-degree phase shift) and amplitude.

The voltage is defined as common-mode in a properly balanced state. The sum of three-phase voltages is always zero.

**Note:** With the exception of high-power motors, bearing protection is essentially not required.

### ELECTRIC MOTORS POWERED THROUGH CONTROL SYSTEMS (FVD CONTROL)

#### Unbalanced voltage conditions

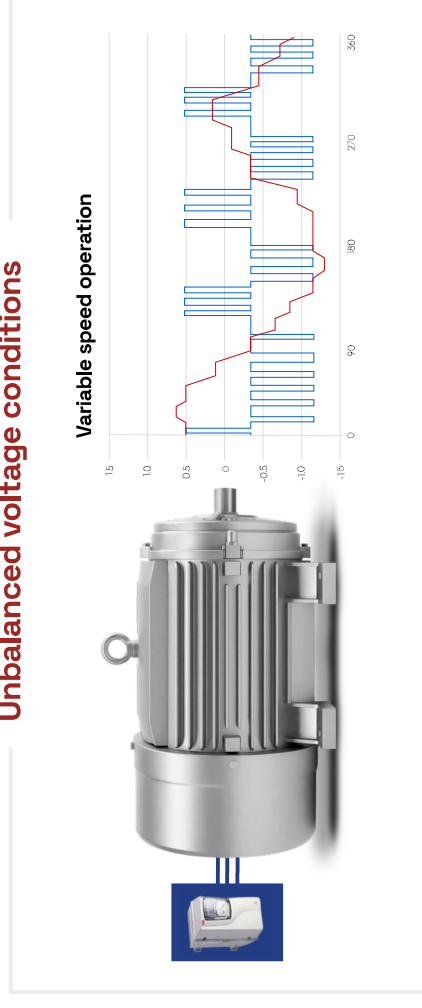

When powered by an inverter, the power supplied to the motor is not a smooth sinusoidal waveform but a series of positive and negative pulses.

The supply voltage is never balanced, as at any given moment it can be positive, negative, or zero, with rapid switching between pulses in each of the three phases.

Common-mode voltage is often referred to as a „square wave” or a „six-step” waveform.



To prevent bearing damage caused by electrical erosion, it is necessary to install protective measures. Shaft voltages and bearing currents are induced by variable frequency drives.

## THE ELECTRIC MOTOR BEHAVES LIKE A CAPACITOR

- Pulses transmitted from the inverter to the motor cause the formation of a common-mode voltage capacitive coupling on the motor shaft.
- This voltage can be measured using a portable Fluke 190 oscilloscope and an EarthRings® shaft voltage probe.
- Causes the generation of electrical currents that discharge through the bearings.

To prevent bearing damage caused by electrical erosion, it is necessary to install protective measures.

Shaft voltages and bearing currents are induced by variable frequency Drives.

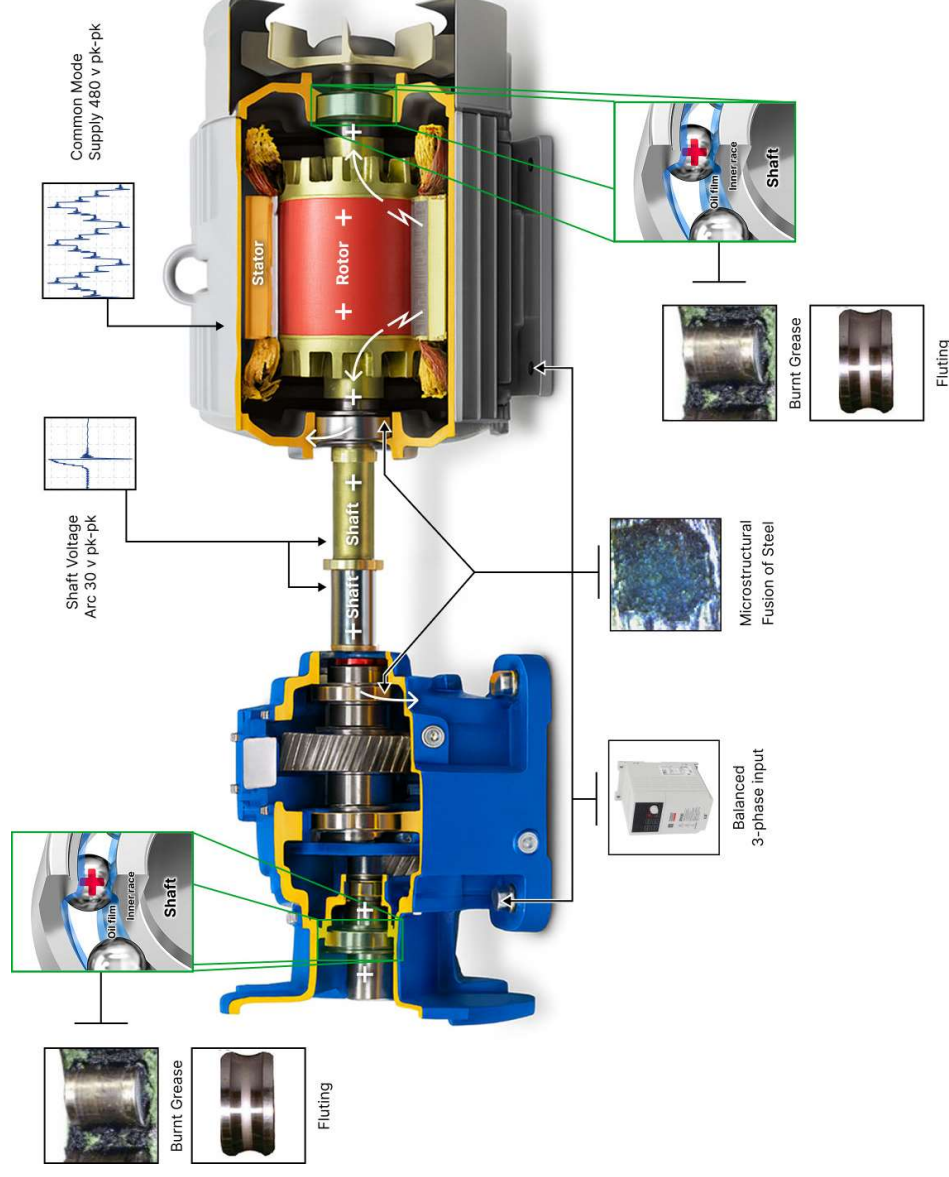

## THERE ARE TWO MAIN SOURCES OF BEARING CURRENTS IN VARIABLE-SPEED AC MOTORS (TYPE A AND B BEARING CURRENTS + 400KW CIRCULATING CURRENTS).

### EDM Current:

This is a capacitive voltage induced on the shaft, which discharges through the motor's bearings. Bearing currents are caused by variable frequency drives that create a parasitic capacitive coupling between the stator and the rotor, which in turn allows current to flow through the bearings.

- These types of currents occur in virtually every motor, from small fractional-kilowatt units to high-power motors.
- These voltages can be discharged through the motor's bearings, leading to electrical pitting and fluting.
- 400Kw circulating currents



### Recommended Practice:

It is recommended to ground the motor shaft using EarthRings® grounding rings. They create a path of least resistance, which allows for the dissipation and diversion of currents away from the motor bearings.

**Total Qualitative Bearing Currents**

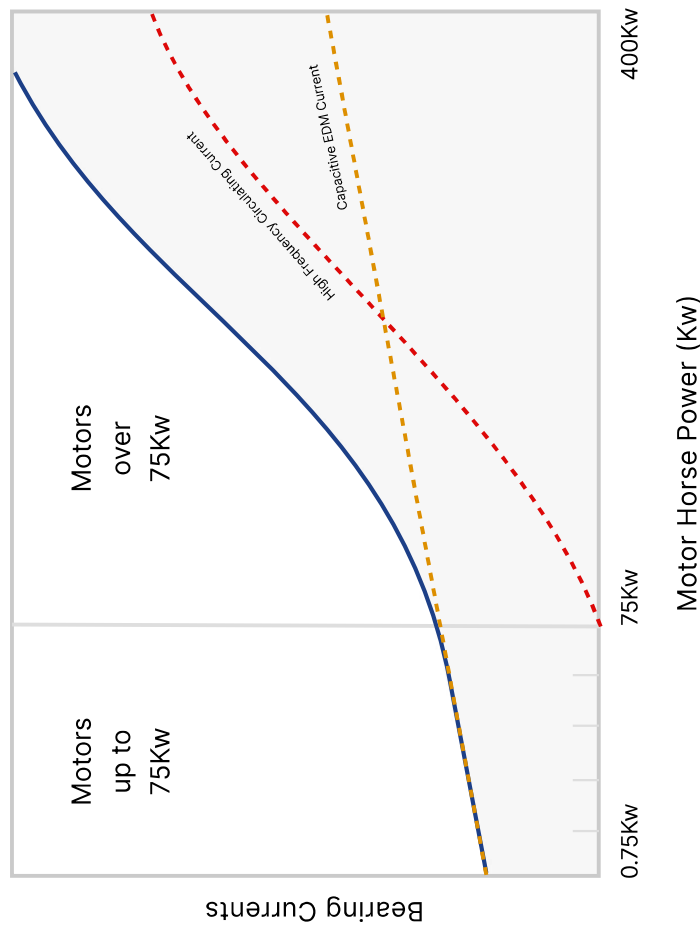

## HIGH-FREQUENCY EDM CURRENTS

### Capacitive EDM Currents A:

High-frequency circulating currents can be generated by a magnetic flux and common-mode currents. These inductive currents, produced by variable frequency drives (VFDs), have frequencies in the kilohertz (kHz) or megahertz (MHz) range.

- They can occur in motors with a power output exceeding 75 kW.
- These currents circulate through the bearings, the motor shaft, and the frame.

### ! Recommended Practice:

The best way to avoid potential bearing damage is to break the path of high-frequency circulating currents. Motors susceptible to Type B currents (high-frequency circulating currents) will also be vulnerable to Type A currents (capacitive shaft voltage). Therefore, the installation of EarthRings® grounding rings is required.

### Total Qualitative Bearing Currents



Capacitive EDM Currents A

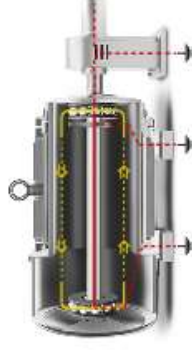

Capacitive EDM Currents and High Frequency Circulating Currents

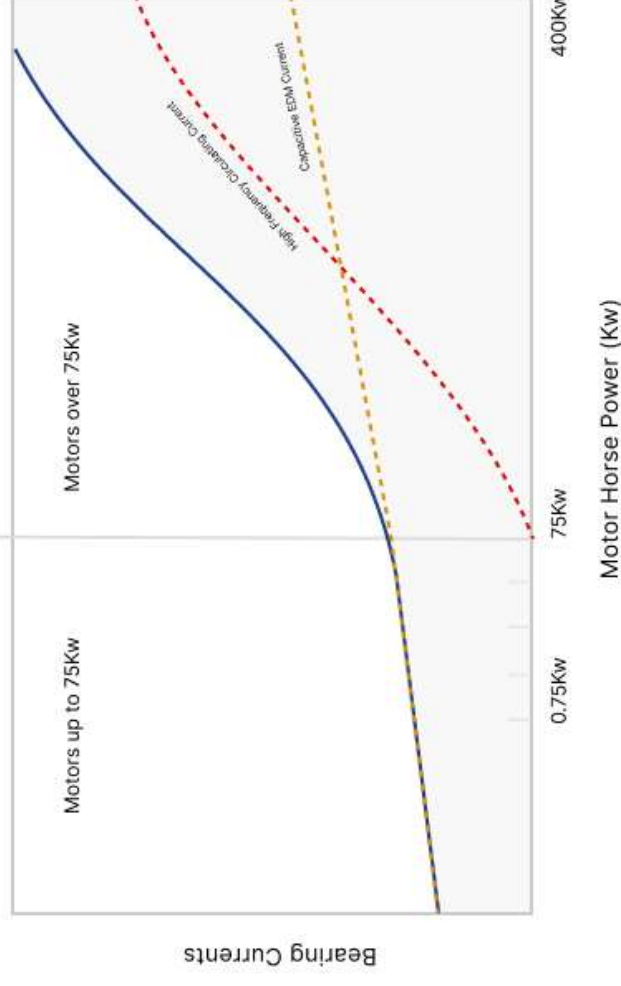

THE THIRD SOURCE OF BEARING CURRENTS ARE CIRCULATING CURRENTS ORIGINATING FROM THE 60 HZ/50 HZ LINE VOLTAGE. THEY OCCUR IN MEDIUM AND HIGH-VOLTAGE MOTORS.

### Circulating Current B:

Due to asymmetrical design, sinusoidal voltage sources can cause circulating currents in larger machines. Similarly, magnetic asymmetry in the motor's construction can lead to circulating currents when powered by a 50/60 Hz current.

- They usually occur only in larger devices.
- These currents circulate through the bearings, the motor shaft, and the frame.
- In motors with a power output exceeding 400Kw, powered by DC current and without a VFD, circulating currents can occur.



#### **Recommended Practice:**

The best way to avoid potential bearing damage is to break the path of the circulating currents.

### Total Qualitative Bearing Currents

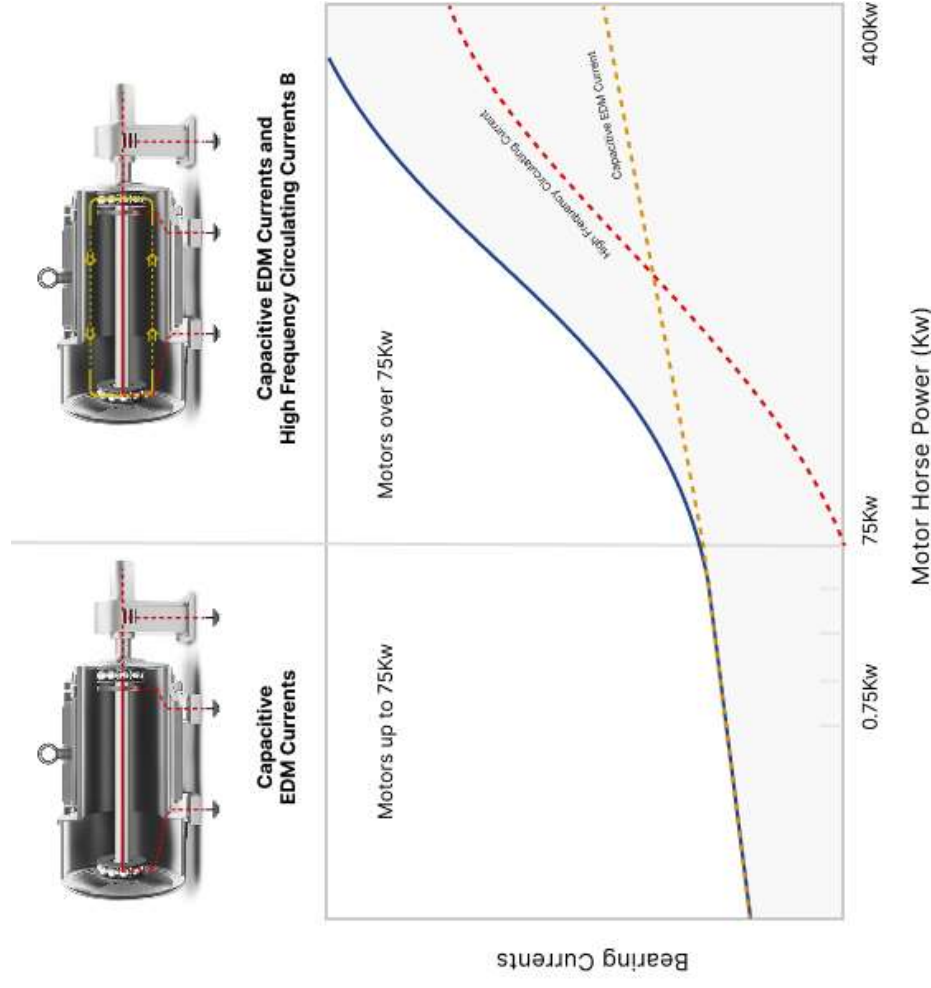

## AC INDUCTION MOTORS

### FREQUENCY CONTROL OPERATION

#### MOTORS UP TO 400 KW

Bearing current A



#### 1 x LV EarthRings®

Installing LV EarthRings® on the Drive  
or Non-Drive Side

#### MOTORS ABOVE 400 KW

Bearing current A and B

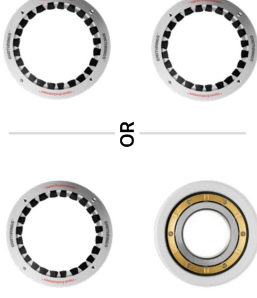

#### HV EarthRings® + insulated bearing or 2 x HV EarthRings®

Installing HV EarthRings® on the side  
opposite the bearing insulation,  
typically on the drive side.

Insulate one bearing, typically on the non-drive side,  
to interrupt the circulating current path, or two  
EarthRings® rings.

### CUTTING AND INSPECTION OF THE BEARING CONDITION

**Inspecting the motor's bearings, especially from a frequency-controlled unit, provides crucial information for determining the best course of action. The report template is available at: [www.earthrings.co.za](http://www.earthrings.co.za).**



## BEARING CROSS-SECTIONING AND INSPECTION

### Bearing inspection



**The bearing and its housing should be inspected, and a grease sample should be retained for analysis.**

They should also be checked for signs of:

- Pollution
- Signs of excessive temperature.
- Hardening/thickening of the grease
- Wrong color (dark grease)
- Excessive grease leakage from the bearing



**Check the grease and check for contamination in the bearing.**

- Carbonated grease: Continuous arcing in engine bearings often causes rapid deterioration of the grease's lubricating properties, contributing to damage to the bearing raceway surfaces. When arcing occurs, the hydrocarbon components of the grease are heated above their decomposition temperature.
- Arcing not only burns the grease but also flakes off small metal particles from the raceway and balls, which then circulate in the lubricant. These highly abrasive particles accelerate bearing wear.



**Cutting and inspection of bearing condition.**

Burnt bearing grease is blackened and often contaminated with metal particles. Burnt bearing grease darkens and is contaminated with metal particles, while new grease comes in many colors.



### Analysis of the Effectiveness of Insulated Bearings and Housings in the Context of Electrical Discharge Machining (EDM)

**Insulated Bearings:** These bearings serve as a countermeasure against Electrical Discharge Machining (EDM). However, it must be emphasized that bearing manufacturers do not guarantee their complete immunity to this phenomenon. A significant limitation is that insulated bearings do not prevent bearing currents from propagating into the driven equipment (such as gearboxes, pump casings, etc.). Consequently, the electrical issue can be transferred to other, previously unaffected areas of the system. When shaft voltages are unable to escape through the motor bearings, there is a **massive increase in current density** flowing through the motor shaft. This condition elevates the risk of ionization, which is critically important in hazardous areas. Furthermore, the initial and ongoing cost of ownership for insulated bearings remains prohibitively high (e.g., in South Africa).

**Insulated Bearing Housings:** Since typically only one insulated end shield is installed, this solution is not **100% effective** in protecting motor bearings against VSD-induced currents. Moreover, capacitive currents differ from Eddy-currents, and utilizing only one insulated housing may merely **increase the shaft currents** in the non-insulated bearings. The practice of employing two insulated housings per motor is not only **exceedingly expensive** but also increases the currents diverted to the driven equipment, along with the associated operational risks.



**Check the bearing for signs of electrical erosion damage. Clean the bearing components with a degreaser or solvent, following all safety precautions.**

Thousands of microscopic pits (5-10 micrometers in diameter) are formed when voltage exceeds the dielectric strength of the grease, causing electrical discharges between the inner raceway, the ball, and the outer raceway.

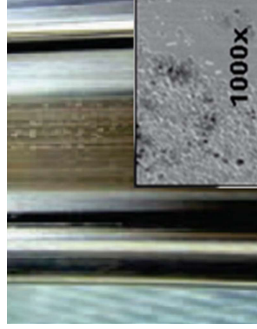

**Frosting appears as a gray, discolored line on a part of or the entire bearing raceway (both inner and outer).**

Although discoloration can be a result of wear, in frequency-controlled motors without bearing protection, it's highly probable that the frosting is caused by electrical erosion. To confirm this, a microscope may be required.



**Fluting is characterized by a washboard -like pattern visible to the naked eye or under 10x magnification.**

It's often mistaken for mechanical bearing damage, making it crucial to correctly identify if the fluting is of electrical origin.



**To determine the root cause of bearing failure, you should consult with other experts in addition to using this guide. When replacing bearings in a frequency-controlled motor, always install a new EarthRings® ring.**

## RECOMMENDED PRACTICES FOR SHAFT GROUNDING WITH EARTHINGS®



### Preparing the shaft for internal and external assembly

EarthRings® rings must not be installed over a keyway, as its sharp edges could damage the conductive layer. For best results, adjust the length of the standoffs and screws to avoid contact with the keyway. Alternatively, you can fill the keyway (in the area where the shaft will contact the ring's microfibers).



### The motor shaft must be conductive:

The motor shaft must be conductive. It cannot be coated with any finish, including paint or other non-conductive materials, so it must be cleaned down to bare metal. Depending on the shaft's condition, it may be necessary to clean it with sandpaper or a Scotch-Brite™ scouring pad. If the shaft appears visually clean, use a non-petroleum-based solvent to remove any residue. If possible, the shaft's conductivity should be measured with an ohmmeter.



### Conductivity measurement:

Connect the ohmmeter leads to the shaft where the microfibers will make contact. The reading will vary depending on the motor, but the maximum value should not exceed 2 ohms. If the reading is higher, clean the shaft again and repeat the measurement.



### Grounding rings test

EarthRings® rings divert harmful shaft voltage to the grounding system, bypassing the bearings. The current flows from the shaft through the conductive fibers, the ring housing, and the mounting components to the motor, and finally to ground. All sections of this high-frequency current path must be conductive.



**To ensure a conductive path to ground, you must remove excess paint from the end cap. It is also necessary to clean all connections.**

## PREPARING THE SHAFT FOR INTERNAL AND EXTERNAL ASSEMBLY



Before installing the EarthRings® ring, the motor shaft must be properly prepared to ensure its electrical conductivity and effective performance:

- The shaft must be cleaned down to bare metal, as it cannot be coated with any paint or other non-conductive material.
- The drive shaft must not be coated with oil, grease, or any other oily substances that could stick the conductive microfibers of the ring together.
- Do not use thread lock to secure the mounting screws, as it may compromise the conductive path to ground.



Install the EarthRings® rings so that the aluminum housing maintains an equal distance from the shaft, and the conductive microfibers make direct contact with the conductive metal surface of the shaft.



**Do not use thread locker when tightening the mounting screws, as it could compromise the conductive path to ground.**

After installation, check the conductivity of the grounding path with an ohmmeter by placing the leads on the metal housing of the EarthRings® ring and the motor frame. The motor must be grounded according to current standards. If exposed to excessive contamination, the EarthRings® ring's microfibers must be protected.

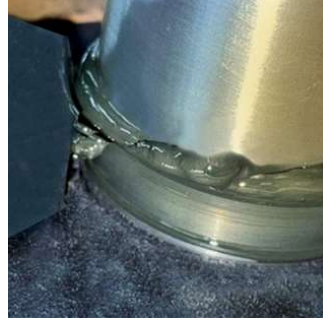

If there's leaking grease or heavy contamination, a seal (O-ring or V-ring) should be installed before the EarthRings® ring. Alternatively, you can purchase the EarthRings® Ultra ring, which incorporates two specialized seals to protect the fibers from excessive dirt and grease.

For support with a specific application, please contact the EarthRings® engineering or customer service department.

## CASE STUDY

### HIGH-FREQUENCY SHAFT VOLTAGE MEASUREMENT

#### EarthRings® SVP probe for measuring voltage on the shaft

The EarthRings® Shaft Voltage Probe tip attaches to an oscilloscope voltage probe to easily and accurately measure the voltage on a rotating shaft. The high density of conductive microfibers ensures continuous contact with the rotating shaft.



#### Measurement and analytical notes - shaft voltage measurementUs

##### Shaft Voltage Measurement Report:

Shaft voltage measurements on frequency-controlled motors provide valuable information to help identify the risk of bearing damage from electrical discharges.

Analyzing the readings and voltage waveforms helps determine the optimal solution. The best time for measurements is during the first startup of a new or repaired motor. These measurements should be part of the preventive and predictive maintenance schedule and can be combined with vibration analysis, thermography, or other services.

## EXAMPLES OF SHAFT VOLTAGE READINGS

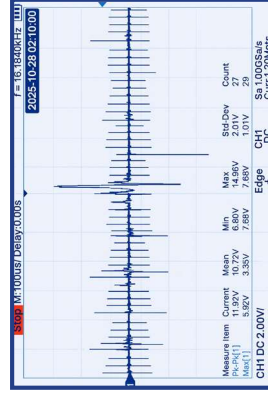

### High Common Mode Peak-to-Peak Voltage

The peak-to-peak voltage typically ranges from 20 to 120 V. The waveform shows the common mode capacitive coupling voltage on the motor shaft. The „6-step” waveform results from the 3-phase pulses generated by a Variable Frequency Drive (VFD). Occasionally, it can resemble a rectangular waveform. This type of waveform often occurs when bearings are not grounded and the shaft voltage reaches its maximum value. At some point, the voltage level can exceed the dielectric strength of most uninsulated bearings, causing the voltage to discharge.

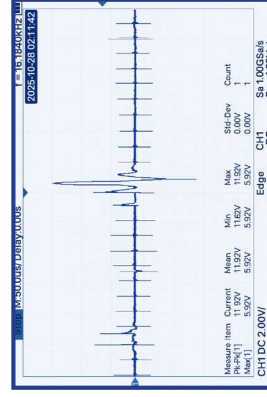

### High Amplitude Electrical Erosion Discharge Waveform

Depending on the motor, bearing type, age, and other factors, electrical erosion discharges typically occur at peak values from 6 V to 80 V. The waveform shows a rise in shaft voltage followed by a steep vertical drop, indicating the voltage discharge. This can happen thousands of times per second, depending on the drive's carrier frequency. The steep vertical discharge drop on the falling edge of the voltage pulse corresponds to an -high dv/dt frequency, with a typical discharge frequency ranging from 1 to 125 MHz (based on measurements under various conditions).

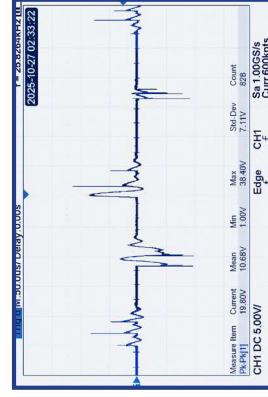

### Low Amplitude Voltage Discharge Waveform

Typical peak-to-peak voltages range from 4 to 15 V. The waveform shows a more consistent discharge pattern with lower dv/dt frequencies, ranging from 30 kHz to 1 MHz. The lower voltage is a result of increased bearing grease conductivity, which allows for a greater current flow. Over time, the grease becomes contaminated with carbon and metal particles, which lowers the impedance for current flow to the shaft, resulting in a reduced peak-to-peak voltage. This condition typically occurs in motors that have been running for many months or years.

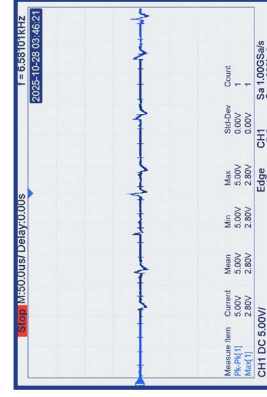

### Peak-to-Peak Voltage with an EarthRings® Ring Installed

After installing an EarthRings® ring on a clean metal shaft, the peak-to-peak voltage typically drops to 1-3 V. These values can be further reduced by applying the EarthRings® colloidal silver conductive coating, which enhances the flow of electrons. The waveform shows a low peak-to-peak voltage, indicating that the EarthRings® ring effectively discharges the shaft voltage.

## PERFORMING THE MEASUREMENT - BACKGROUND NOISE

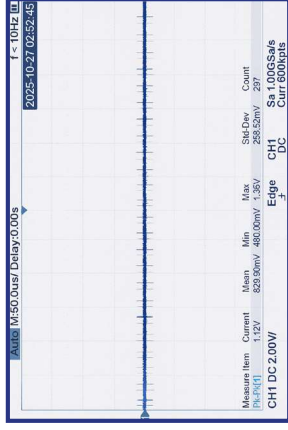
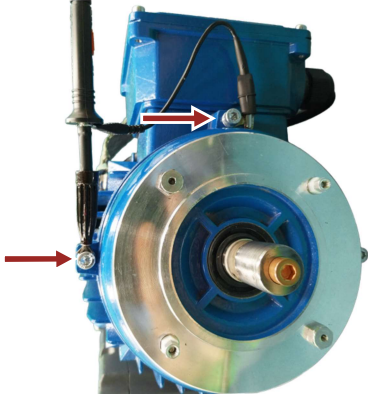

### Reference Ground Reading (EMI):

The reading shows background noise (EMI) generated by the motor/drive system. This electrical noise may be present both before and after installing the EarthRings® ring.

- 01.** Locate two ground points on the motor. They must be cleaned down to bare metal to ensure conductivity.
- 02.** Place the probe on one point and the probe's ground clip on the other.
- 03.** Measurement results will vary depending on the motor size and other conditions.

**⚠** When working with rotating equipment, you must always follow all safety recommendations.

## PERFORMING THE MEASUREMENT - SHAFT VOLTAGE

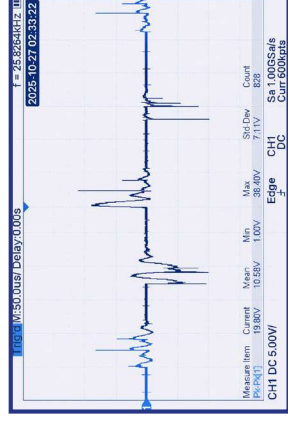
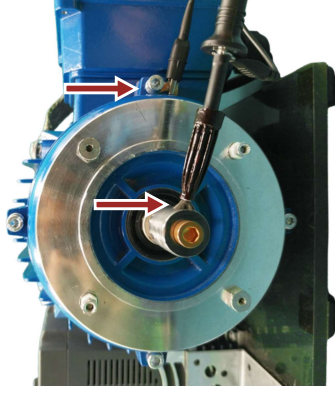

### Shaft Voltage Reading:

The reading shows background noise (EMI) generated by the motor/drive system. This electrical noise may be present both before and after installing the EarthRings® ring.

- 01.** The shaft must be clean and free of any coatings, including paint or other non-conductive materials.
- 02.** Secure the probe with a magnetic base.
- 03.** Apply the EarthRings® probe tip to the face or side of the shaft, ensuring continuous contact. Avoid applying it to the keyway.
- 04.** Connect the oscilloscope's ground led to a spot on the motor where bare metal provides a conductive path to ground.
- 05.** If a report is being created for a client, save the signal waveform image.

## MEASUREMENTS USING THE EARTHRINGS® GROUNDING SIMULATOR

The EarthRings® Grounding Simulator tip simulates the change in shaft voltage after an EarthRings® ring is installed. This is a quick way to demonstrate the „before and after” state.

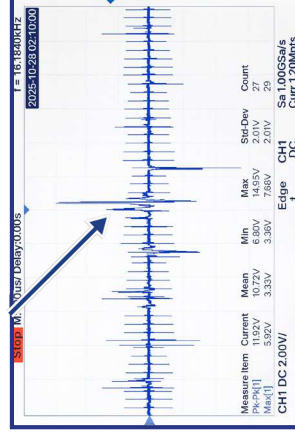
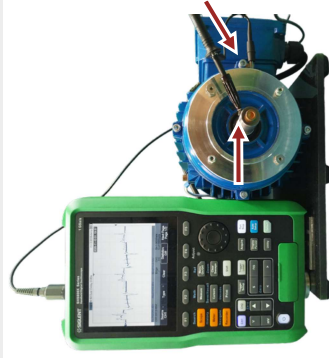

### Shaft Voltage Measurement without Grounding:

01. Ensure the shaft is clean, with no coatings (including paint) or other non-conductive materials.
  02. Secure the probe with a magnetic base.
  03. Apply the EarthRings® probe tip to the face or side of the shaft, ensuring continuous contact. Avoid applying it to the keyway.
  04. Connect the oscilloscope's ground lead to a spot on the motor where bare metal provides a path to ground.
  05. Save the image.
- A peak-to-peak voltage of 31.2 V is an example of voltage discharging through the bearings when an EarthRings® ring is not installed.

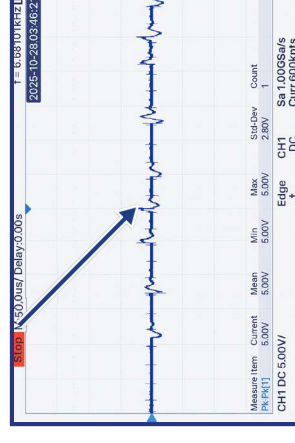
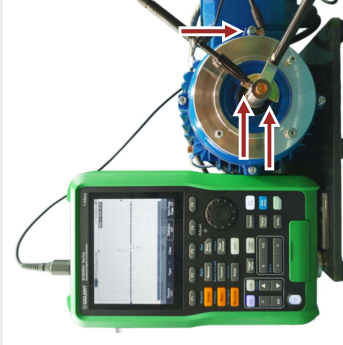

### Shaft Voltage Measurement using the Grounding Simulator Tip:

01. Use the same setup as the previous measurement.
02. Apply the EarthRings® Grounding Simulator's grounding clip to a spot on the motor where bare metal provides a path to ground.
03. Apply the simulator tip to the shaft to simulate the presence of the EarthRings® ring.
04. Save the image.

An example measurement of 1.2 V peak-to-peak voltage shows how the voltage is discharged to ground by the simulator. The EarthRings® bearing protection ring will perform similarly or even better.



**When working with rotating equipment, you must always follow all safety recommendations.**

## SOLUTION

### SELECTING THE PROPER RING SIZE



For standard NEMA or IEC frame motors, the EarthRings® ARC is the best choice. It allows the ring to be mounted behind the shaft shoulder and seal. The kit includes 4 different bracket sizes that fit most applications.



You should ask: **Is there a shoulder on the motor shaft?**



If the answer is **YES** or „not sure,“ the **EarthRings® LV & HL ARC** is the best solution as it allows you to move the ring away from the shoulder, seals, or an irregularly shaped end cover.

The EarthRings® ARC is mounted using the included screws with washers.



If the answer is **NO**, the ring can be mounted directly to the end cover using screws or presfit instalation into the nest.

Then, find the correct catalog number for the ring with your chosen mounting method from the parts list.



If the answer is **YES** and the ring will be mounted on the shaft shoulder: measure the length and diameter of the shaft shoulder. Then, based on the Product list, find the appropriate model number for the EarthRings®

## LIST EARTHINGS® LV & LH ARC

DIMENSIONS IN MM

### ARC LV AND HV SIZING CHART METRIC

SHAFT DIAMETER	ARC LV AND HV SIZING CHART METRIC												
	20mm to 40mm	40mm to 60mm	60mm to 80mm	80mm to 100mm	90mm to 110mm	100mm to 120mm	120mm to 140mm	140mm to 160mm	160mm to 180mm	180mm to 200mm	200mm to 220mm	220mm to 240mm	240mm to 260mm
20	40	60	80	90	100	120	140	160	180	200	220	240	
22	42	62	82	92	102	122	142	162	182	202	222	242	
24	44	64	84	94	104	124	144	164	184	204	224	244	
26	46	66	86	96	106	126	146	166	186	206	226	246	
28	48	68	88	98	108	128	148	168	188	208	228	248	
30	50	70	90	100	110	130	150	170	190	210	230	250	
32	52	72	92	102	112	132	152	172	192	212	232	252	
34	54	74	94	104	114	134	154	174	194	214	234	254	
36	56	76	96	106	116	136	156	176	196	216	236	256	
38	58	78	98	108	118	138	158	178	198	218	238	258	
40	60	80	100	110	120	140	160	180	200	220	240	260	

**EARTHINGS™**

**YOUR FIRST LINE OF DEFENSE AGAINST BEARING FAILURE**

2026 MANUAL